

# SAE 1141 (NbFG) Normalized Steel Iteration #13

Fatigue Behavior, Monotonic Properties  
and  
Microstructural Data

Prepared by:

M. Roessle  
and  
A. Fatemi

Department of Mechanical, Industrial and  
Manufacturing Engineering  
The University of Toledo  
Toledo, Ohio 43606

Prepared for:  
The AISI Bar Steel Applications Group

April 1998



American Iron and Steel Institute  
2000 Town Center, Suite 320  
Southfield, Michigan 48075  
tel: 248-945-4777  
fax: 248-352-1740  
[www.autosteel.org](http://www.autosteel.org)

## NOMENCLATURE

$A_o, A_f$	initial, final area	$S$	engineering stress
HB, HRB, HRC	Brinell, Rockwell B-Scale, Rockwell C-Scale hardness number	YS, UYS, LYS, YS'	monotonic yield, upper yield, lower yield, cyclic yield strength
b, c, n	fatigue strength, fatigue ductility, strain hardening exponent	YPE	yield point elongation
$D_o, D_f$	initial, final diameter	$S_u$	ultimate tensile strength
e	engineering strain	%EL	percent elongation
E, E'	monotonic, midlife cycle modulus of elasticity	%RA	percent reduction in area
K, K'	monotonic, cyclic strength coefficient	$\sigma, \sigma_f, \sigma_f'$	true stress, true fracture strength, fatigue strength coefficient
$L_o, L_f$	initial, final gage length	$\sigma_a, \sigma_m, \Delta\sigma$	stress amplitude, mean stress, stress range
$N_{50\%},$ $(N_f)_{10\%},$ $(N_f)_{50\%},$	number of cycles to midlife, 10% load drop, 50% load drop	$\epsilon_e, \epsilon_p, \epsilon$	true elastic, plastic, total strain
$2N_f$	reversals to failure	$\epsilon_f, \epsilon_f'$	true fracture ductility, fatigue ductility coefficient
$P_f, P_u$	fracture, ultimate load	$\epsilon_a, \epsilon_m, \Delta\epsilon$	strain amplitude, mean strain, strain range
R	neck radius; or strain ratio	$\Delta\epsilon_e, \Delta\epsilon_p$	elastic, plastic strain range

## UNIT CONVERSION TABLE

<u>Measure</u>	<u>SI Unit</u>	<u>US Unit</u>	<u>from SI to US</u>	<u>from US to SI</u>
Length	mm	in	1 mm = 0.03937 in	1 in = 25.4 mm
Area	mm <sup>2</sup>	in <sup>2</sup>	1 mm <sup>2</sup> = 0.00155 in <sup>2</sup>	1 in <sup>2</sup> = 645.16 mm <sup>2</sup>
Load	kN	klb	1kN = 0.2248 klb	1 klb = 4.448 kN
Stress	MPa	ksi	1 MPa = 0.14503 ksi	1 ksi = 6.895 MPa
Temperature	°C	°F	°C = (°F - 32)/1.8	°F = (°C * 1.8) + 32

In SI Unit:

$$1 \text{ kN} = 10^3 \text{ N} \quad 1 \text{ Pa} = 1 \text{ N/m}^2 \quad 1 \text{ MPa} = 10^6 \text{ Pa} = 1 \text{ N/mm}^2 \quad 1 \text{ Gpa} = 10^9 \text{ Pa}$$

In US Unit:

$$1 \text{ klb} = 10^3 \text{ lb} \quad 1 \text{ psi} = 1 \text{ lb/in}^2 \quad 1 \text{ ksi} = 10^3 \text{ psi}$$

# TABLE OF CONTENTS

<b>SUMMARY .....</b>	<b>1</b>
<b>I. EXPERIMENTAL PROGRAM .....</b>	<b>2</b>
1.1 MATERIAL AND SPECIMEN FABRICATION .....	2
1.1.1 <i>Material</i> .....	2
1.1.2 <i>Specimen</i> .....	2
1.2 TESTING EQUIPMENT .....	3
1.2.1 <i>Apparatus</i> .....	3
1.2.2 <i>Alignment</i> .....	4
1.3 TEST METHODS AND PROCEDURES .....	5
1.3.1 <i>Monotonic tension tests</i> .....	5
1.3.2 <i>Constant amplitude fatigue tests</i> .....	6
<b>II. EXPERIMENTAL RESULTS AND ANALYSIS.....</b>	<b>8</b>
2.1 MICROSTRUCTURAL DATA .....	8
2.2 MONOTONIC DEFORMATION BEHAVIOR .....	8
2.3 CYCLIC DEFORMATION BEHAVIOR .....	11
2.3.1 <i>Transient cyclic deformation</i> .....	11
2.3.2 <i>Steady-state cyclic deformation</i> .....	11
2.4 CONSTANT AMPLITUDE FATIGUE BEHAVIOR .....	13
<b>REFERENCES.....</b>	<b>26</b>
<b>APPENDIX.....</b>	<b>27</b>

## SUMMARY

The microstructural data, monotonic properties, and fatigue behavior data have been obtained for SAE 1141 (NbFG) normalized steel. The material was provided by the American Iron and Steel Institute (AISI). Microstructural data includes grain type, grain size, and inclusion content. Three tensile tests were performed to acquire the desired monotonic properties. Eighteen strain-controlled fatigue tests were performed to obtain the strain-life and cyclic stress-strain curves and properties. The experimental procedure followed and results obtained are presented and discussed in this report.

# I. EXPERIMENTAL PROGRAM

## 1.1 Material and Specimen Fabrication

### 1.1.1 Material

The SAE 1141 (NbFG) normalized steel was manufactured by North Star Steel. This material was normalized at 1650 °F and was delivered to the University of Toledo in rolled form. The bars were approximately 0.97 inches in diameter prior to machining. In Table 1, the chemical composition supplied by North Star Steel is shown.

### 1.1.2 Specimen

In this study, identical round specimens were used for the monotonic and fatigue tests. The specimen configuration and dimensions are shown in Figure 1. This configuration deviates slightly from the specimens recommended by ASTM Standard E606 [1]. The recommended specimens have uniform or hourglass test sections. The specimen geometry shown in Figure 1 differs by using a large secondary radius throughout the test section.

All specimens were machined in the Mechanical, Industrial, and Manufacturing Engineering Machine Shop at the University of Toledo. The specimens were initially turned on a lathe to an appropriate diameter for insertion into a CNC machine. Using the CNC machine, final turning was performed to achieve the tolerable dimensions specified on the specimen drawings.

A commercial round-specimen polishing machine was used to polish the specimen gage section. Four different grits of aluminum oxide lapping film were used: 30 $\mu$ , 12 $\mu$ , 9 $\mu$ , and 3 $\mu$ . The 3 $\mu$  grit was used as the final polish and polishing marks coincided with the specimens' longitudinal direction. The polished surfaces were carefully examined under magnification to ensure complete removal of machine marks within the test section.

## **1.2 Testing Equipment**

### **1.2.1 Apparatus**

An MTS closed-loop servo-controlled hydraulic axial load frame in conjunction with a Schenck-Pegasus digital servo-controller were used to conduct the tests. The calibration of this system was verified prior to beginning the test program. The load cell used had a capacity of 22 klb. Hydraulically operated grips using universal tapered collets were employed to secure the specimens' ends in series with the load cell.

Total strain was controlled for all tests using an extensometer rated as ASTM class B1 [2]. The calibration of the extensometer was verified using displacement apparatus containing a micrometer barrel in divisions of 0.0001 in. The extensometer had a gage length of 0.30 in and was capable of measuring strains up to 15 %.

In order to protect the specimens' surface from the knife edges of the extensometer, ASTM Standard E606 recommends the use of transparent tape or epoxy to 'cushion' the attachment. For this study, it was found that application of transparent tape strips was difficult due to the radius within the test section. Therefore, epoxy was considered to be the best protection. One disadvantage of epoxy is the variability of

mixtures throughout the test program. As an alternative to epoxy, M-coat D offered a more consistent mixture. Therefore, the tests were performed using M-coat D.

All tests were conducted at room temperature and were monitored using a digital thermometer. In order to minimize temperature effects upon the extensometer and load cell calibrations, fluctuations were maintained within  $\pm 2$  °C ( $\pm 3.6$  °F) as required by ASTM Standard E606. Also, the relative humidity of the air was monitored using a precision hydrometer.

### **1.2.2 Alignment**

Significant effort was put forth to align the load train (load cell, grips, specimen, and actuator). Misalignment can result from both tilt and offset between the central lines of the load train components. According to ASTM Standard E606, the maximum bending strains should not exceed 5 % of the minimum axial strain range imposed during any test program. For this study, the minimum axial strain range was 0.0032 in/in. Therefore, the maximum allowable bending strain was 160 microstrain. ASTM Standard E1012, Type A, Method 1 was followed to verify specimen alignment [3]. For this procedure, two arrays of four strain gages per array were arranged at the upper and lower ends of the uniform gage section. For each array, gages were equally spaced around the circumference of a 0.25 in. diameter specimen with uniform gage section. The maximum bending strain determined from the gaged specimen (using static tensile and compressive loads) was approximately 35 microstrain. This value was well within the allowable ASTM limit.



## 1.3 Test Methods and Procedures

### 1.3.1 Monotonic tension tests

All monotonic tests in this study were performed using test methods specified by ASTM Standard E8 [4]. Three specimens were used to obtain the monotonic properties. Due to the limitations of the extensometer, strain control was used only up to 14% strain. After this point, displacement control was used until fracture. By utilizing an x-y plotter, a load versus strain plot was obtained for each test.

For the elastic and initial yield region (0% to 0.5% strain), a strain rate of 0.0025 in/in/min was chosen. This strain rate was three-quarters of the maximum allowable rate specified by ASTM Standard E8 for the initial yield region. After yielding (0.5% to 14% strain), the strain rate was increased by a factor of three (i.e., 0.0075 in/in/min). After the extensometer was removed, a displacement rate of 0.01275 in/min was used. This displacement rate provided approximately the same strain rate as that used prior to switching control modes.

After the tension tests were concluded, the broken specimens were carefully reassembled. The final gage lengths of the fractured specimens were measured with a Vernier caliper having divisions of 0.001 in. Using an optical comparator with 10X magnification and divisions of 0.001 in, the final diameter and the neck radius were measured. It should be noted that prior to the test, the initial minimum diameter was measured with this same instrument.

### 1.3.2 Constant amplitude fatigue tests

All constant amplitude fatigue tests in this study were performed according to ASTM Standard E606. It is recommended by this standard that at least 10 specimens be used to generate the fatigue properties. For this study, 18 specimens at 6 different strain amplitudes ranging from 0.16% to 1.5% were utilized. Three methods were used to record data throughout each test. First, an x-y plotter was used to record the initial hysteresis loops. After several cycles (as time permitted), both the maximum and minimum load and strain values were manually tabulated from the controller screen digital readouts. Also, a printer was connected directly to the controller. This allowed hysteresis loops to be recorded from the controller's built-in oscilloscope.

There were two control modes used for these tests. Strain control was used in all tests, except the run-out tests. For the run-out tests (greater than  $10^6$  cycles), strain control was used initially to determine the stabilized load. Then stress control was used for the remainder of the test. The reason for the change in control mode was due to limitations on the extensometer. For the strain control tests, the applied frequencies ranged from 0.33 Hz to 3 Hz in order to keep a constant strain rate of 0.02 in/in/sec. For the stress control tests, the frequency was increased to 30 Hz in order to shorten the overall test duration. All tests were conducted using a triangular waveform.

To estimate and initially plan the strain level for a desired life, the modified universal slopes method by Muralidharan and Manson was used. According to research by Park and Song [5], the modified universal slopes method was concluded to be the best

correlation of the currently available methods. This correlation is given by:

$$\frac{\Delta\varepsilon}{2} = 0.623 \left( \frac{S_u}{E} \right)^{0.832} (2N_f)^{-0.09} + 0.0196 (\varepsilon_f)^{0.155} \left( \frac{S_u}{E} \right)^{-0.53} (2N_f)^{-0.56} \quad (1)$$

This correlation utilizes material properties determined from monotonic tests.

## II. EXPERIMENTAL RESULTS AND ANALYSIS

### 2.1 Microstructural Data

Photomicrographs of the microstructure were obtained using an optical microscope with a Polaroid camera attachment. It was observed that the grains in the transverse and longitudinal directions had negligible difference. In Figure 2, an example of the grains in the longitudinal direction (L-T) is shown at 500X magnification. It can be seen from this photomicrograph that SAE 1141 (NbFG) normalized steel had a ferritic-pearlitic microstructure. In Figure 3, an example of the inclusions/voids in the longitudinal direction (L-T) is shown at 100X magnification. For Figures 2 and 3, the rolling direction is horizontal to the page.

The average grain size was measured in both transverse and longitudinal directions using the comparison procedure reported in ASTM Standard E112 [6]. According to ASTM Standard E45, method A, the inclusion rating numbers for type A, B, C, and D inclusions were found [7]. Brinell and Rockwell hardness tests were also performed. A summary of the microstructural data for SAE 1141 (NbFG) normalized steel is provided in Table 2.

### 2.2 Monotonic Deformation Behavior

The properties determined from monotonic tests were the following: modulus of elasticity (E), yield strength (YS), upper yield strength (UYS), lower yield strength (LYS), yield point elongation (YPE), ultimate tensile strength ( $S_u$ ), percent elongation

(%EL), percent reduction in area (%RA), true fracture strength ( $\sigma_f$ ), true fracture ductility ( $\epsilon_f$ ), strength coefficient (K), and strain hardening exponent (n).

True stress ( $\sigma$ ), true strain ( $\epsilon$ ), and true plastic strain ( $\epsilon_p$ ) were calculated from engineering stress (S) and engineering strain (e), according to the following relationships which are based on constant volume assumption:

$$\sigma = S(1 + e) \quad (2a)$$

$$\epsilon = \ln(1 + e) \quad (2b)$$

$$\epsilon_p = \epsilon - \epsilon_e = \epsilon - \frac{\sigma}{E} \quad (2c)$$

The true stress ( $\sigma$ ) - true strain ( $\epsilon$ ) plot is often represented by the Ramberg-Osgood equation:

$$\epsilon = \epsilon_e + \epsilon_p = \frac{\sigma}{E} + \left( \frac{\sigma}{K} \right)^{\frac{1}{n}} \quad (3)$$

The strength coefficient, K, and strain hardening exponent, n, are the intercept and slope of the best line fit to true stress ( $\sigma$ ) versus true plastic strain ( $\epsilon_p$ ) data in log-log scale:

$$\sigma = K (\epsilon_p)^n \quad (4)$$

In accordance with ASTM Standard E739 [8], when performing the least squares fit, the true plastic strain ( $\epsilon_p$ ) was the independent variable and the stress ( $\sigma$ ) was the dependent variable. These plots for the three tests conducted are shown in Figure 4. To generate the K and n values, the range of data used in this figure was chosen according to the definition of discontinuous yielding specified in ASTM Standard E646 [9]. Therefore,

the valid data range occurred between the end of yield point extension and the strain at or prior to maximum load.

The true fracture strength,  $\sigma_f$ , was corrected for necking according to the Bridgman correction factor [10]:

$$\sigma_f = \frac{\frac{P_f}{A_f}}{\left(1 + \frac{4R}{D_f}\right) \ln\left(1 + \frac{D_f}{4R}\right)} \quad (5)$$

where  $P_f$  is the load at fracture,  $R$  is the neck radius, and  $D_f$  is the diameter at fracture.

The true fracture ductility,  $\epsilon_f$ , was calculated from the relationship based on constant volume:

$$\epsilon_f = \ln\left(\frac{A_o}{A_f}\right) = \ln\left(\frac{1}{1 - RA}\right) \quad (6)$$

where  $A_f$  is the cross-sectional area at fracture,  $A_o$  is the original cross-sectional area, and  $RA$  is the reduction in area.

A summary of the monotonic properties for SAE 1141 (NbFG) normalized steel is provided in Table 2. The monotonic stress-strain curves are shown in Figure 5. As can be seen from this figure, the three curves are very close to each other. Refer to Table A.1 in the Appendix for a summary of the monotonic test results.

## **2.3 Cyclic Deformation Behavior**

### **2.3.1 Transient cyclic response**

Transient cyclic response describes the process of cyclic-induced change in deformation resistance of a material. Data obtained from constant amplitude strain-controlled fatigue tests were used to determine this response. Plots of stress amplitude variation versus applied number of cycles can indicate the degree of transient cyclic softening/hardening. Also, these plots show when cyclic stabilization occurs. A composite plot of the transient cyclic response for SAE 1141 (NbFG) normalized steel is shown in Figure A.1 of the Appendix. The transient response was normalized on the rectangular plot in Figure A.1a, while a semi-log plot is shown in Figure A.1b. Even though multiple tests were conducted at each strain amplitude, data from one test at each strain amplitude tested are shown in these plots.

### **2.3.2 Steady-state cyclic deformation**

Another cyclic behavior of interest was the steady-state or stable response. Data obtained from constant amplitude strain-controlled fatigue tests were also used to determine this response. The properties determined from the steady-state hysteresis loops were the following: cyclic modulus of elasticity ( $E'$ ), cyclic strength coefficient ( $K'$ ), cyclic strain hardening exponent ( $n'$ ), and cyclic yield strength ( $YS'$ ). As can be seen from Figures A.1, the material stabilizes early in life. Half-life (midlife) hysteresis loops and data were used to obtain the stable cyclic properties.

Similar to monotonic behavior, the cyclic true stress-strain behavior can be characterized by the Ramberg-Osgood type equation:

$$\frac{\Delta \varepsilon}{2} = \frac{\Delta \varepsilon_e}{2} + \frac{\Delta \varepsilon_p}{2} = \frac{\Delta \sigma}{2 E} + \left( \frac{\Delta \sigma}{2 K'} \right)^{\frac{1}{n'}} \quad (7)$$

It should be noted that in Equation 7 and the other equations that follow, E is the average modulus of elasticity which was calculated from the monotonic tests.

The cyclic strength coefficient, K', and cyclic strain hardening exponent, n', are the intercept and slope of the best line fit to true stress amplitude ( $\Delta\sigma/2$ ) versus true plastic strain amplitude ( $\Delta\varepsilon_p/2$ ) data in log-log scale:

$$\frac{\Delta \sigma}{2} = K' \left( \frac{\Delta \varepsilon_p}{2} \right)^{n'} \quad (8)$$

In accordance with ASTM Standard E739, when performing the least squares fit, the true plastic strain amplitude ( $\Delta\varepsilon_p/2$ ) was the independent variable and the stress amplitude ( $\Delta\sigma/2$ ) was the dependent variable. The true plastic strain amplitude was calculated by the following equation:

$$\frac{\Delta \varepsilon_p}{2} = \frac{\Delta \varepsilon}{2} - \frac{\Delta \sigma}{2 E} \quad (9)$$

This plot is shown in Figure 6.

The cyclic stress - strain curve reflects the resistance of a material to cyclic deformation and can be vastly different from the monotonic stress - strain curve. The cyclic stress - strain curve is shown in Figure 7. In Figure 8, superimposed plots of monotonic and cyclic curves are shown. As can be seen in Figure 8, SAE 1141 (NbFG) normalized steel has mixed cyclic hardening behavior. Initially, this material cyclically softens, but then becomes cyclically hardened. Figure A.2 in the Appendix shows a composite plot of the steady-state (midlife) hysteresis loops. Even though multiple tests



were conducted at each strain amplitude, the stable loops from only one test at each strain amplitude are shown in this plot.

## 2.4 Constant Amplitude Fatigue Behavior

Constant amplitude strain-controlled fatigue tests were performed to determine the strain-life curve. The following equation relates the true strain amplitude to the fatigue life:

$$\frac{\Delta \varepsilon}{2} = \frac{\Delta \varepsilon_e}{2} + \frac{\Delta \varepsilon_p}{2} = \frac{\sigma_f'}{E} (2 N_f)^b + \varepsilon_f' (2 N_f)^c \quad (11)$$

where  $\sigma_f'$  is the fatigue strength coefficient,  $b$  is the fatigue strength exponent,  $\varepsilon_f'$  is the fatigue ductility coefficient,  $c$  is the fatigue ductility exponent,  $E$  is the monotonic modulus of elasticity, and  $2N_f$  is the number of reversals to failure (which was defined as a 50% load drop, as recommended by ASTM Standard E606).

The fatigue strength coefficient,  $\sigma_f'$ , and fatigue strength exponent,  $b$ , are the intercept and slope of the best line fit to true stress amplitude ( $\Delta\sigma/2$ ) versus reversals to failure ( $2N_f$ ) data in log-log scale:

$$\frac{\Delta \sigma}{2} = \sigma_f' (2 N_f)^b \quad (12)$$

In accordance with ASTM Standard E739, when performing the least squares fit, the stress amplitude ( $\Delta\sigma/2$ ) was the independent variable and the reversals to failure ( $2N_f$ ) was the dependent variable. This plot is shown in Figure 9. To generate the  $\sigma_f'$  and  $b$  values, the range of data used in this figure was chosen for  $N_f \leq 10^6$  cycles.

The fatigue ductility coefficient,  $\epsilon_f'$ , and fatigue ductility exponent,  $c$ , are the intercept and slope of the best line fit to calculated true plastic strain amplitude ( $\Delta\epsilon_p/2$ ) versus reversals to failure ( $2N_f$ ) data in log-log scale:

$$\left(\frac{\Delta\epsilon_p}{2}\right)_{\text{calculated}} = \epsilon_f' (2N_f)^c \quad (13)$$

In accordance with ASTM Standard E739, when performing the least squares fit, the calculated true plastic strain amplitude ( $\Delta\epsilon_p/2$ ) was the independent variable and the reversals to failure ( $2N_f$ ) was the dependent variable. The calculated true plastic strain amplitude was determined from Equation 9. This plot is shown in Figure 10. To generate the  $\epsilon_f'$  and  $c$  values, the range of data used in this figure was chosen for  $N_f \leq 10^6$  cycles.

The true strain amplitude versus reversals to failure plot is shown in Figure 11. This plot displays the strain - life curve (Eqn. 11), the elastic strain portion (Eqn. 12), the plastic strain portion (Eqn. 13), and superimposed fatigue data. A summary of the cyclic properties for SAE 1141 (NbFG) normalized steel is provided in Table 2. Table A.2 in the Appendix provides the summary of the fatigue test results.

Table 1: Chemical composition of SAE 1141 (NbFG) normalized steel

<u>Element</u>	<u>Wt. %</u>
Carbon, C	0.39%
Manganese, Mn	1.42%
Phosphorus, P	0.017%
Sulfur, S	0.096%
Silicon, Si	0.17%
Copper, Cu	0.16%
Nickel, Ni	0.06%
Chromium, Cr	0.13%
Molybdenum, Mo	0.03%
Niobium, Nb	0.025%
Tin, Sn	0.008%

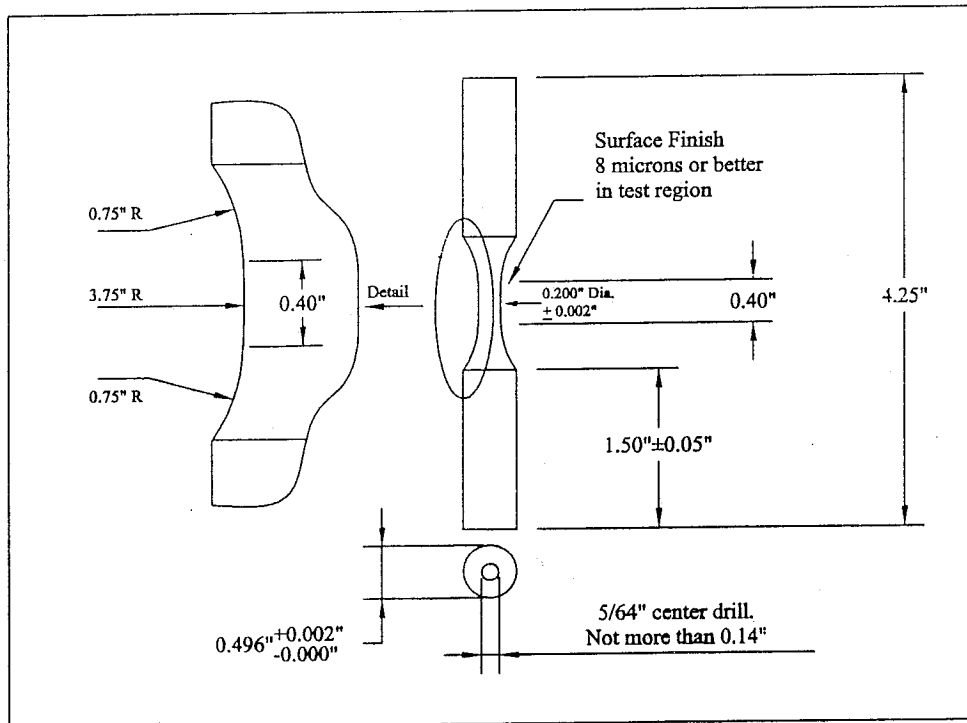

Figure 1: Specimen configuration and dimensions

**Table 2: Summary of the Mechanical Properties**

<b>Microstructural Data</b>	<b>Average</b>		
<u>ASTM grain size number:</u>			
Transverse direction	7 to 9		
Longitudinal direction	7 to 9		
<u>Inclusion rating number:</u>			
Type A (sulfide type), thin series	2		
Type B (alumina type), thin series	none		
Type C (silicate type), thin series	none		
Type D (globular type), thin series	none		
<u>Hardness:</u>			
Brinell (HB)	199.0		
Rockwell B-scale (HRB)	92.5		
Microstructure type:	ferrite/pearlite		

<b>Monotonic Properties</b>	<b>Average</b>	<b>Range</b>
Modulus of elasticity, E, GPa (ksi):	220.2 (31,938.5)	215.8 - 225.9 (31,294.0 - 32,759.9)
Yield strength (0.2% offset), YS, MPa (ksi):	417.8 (60.6)	412.2 - 421.9 (59.8 - 61.2)
Upper yield strength UYS, MPa (ksi):	422.6 (61.3)	419.0 - 429.6 (60.8 - 62.3)
Lower yield strength LYS, MPa (ksi):	414.0 (60.0)	410.0 - 419.6 (59.5 - 60.9)
Yield point elongation, YPE (%):	0.73%	0.72% - 0.74%
Ultimate strength, S <sub>u</sub> , MPa (ksi):	695.2 (100.8)	692.3 - 696.8 (100.4 - 101.1)
Percent elongation, %EL (%):	35%	33% - 36%
Percent reduction in area, %RA (%):	53%	51% - 55%
Strength coefficient, K, MPa (ksi):	1,286.8 (186.6)	1,274.9 - 1,295.9 (184.9 - 187.9)
Strain hardening exponent, n:	0.2174	0.2129 - 0.2243
True fracture strength, σ <sub>f</sub> *, MPa (ksi):	999.5 (145.0)	805.5 - 1109.0 (116.8 - 160.8)
True fracture ductility, ε <sub>f</sub> (%):	76%	72% - 81%

<b>Cyclic Properties</b>	<b>Average</b>	<b>Range</b>
Cyclic modulus of elasticity, E', GPa (ksi):	199.2 (28,886.8)	187.4 - 216.4 (27,176.0 - 31,385.2)
Fatigue strength coefficient, σ <sub>f</sub> ', MPa (ksi):	1,116.6 (161.9)	
Fatigue strength exponent, b:	-0.0962	
Fatigue ductility coefficient, ε <sub>f</sub> ' :	0.2644	
Fatigue ductility exponent, c:	-0.4625	
Cyclic yield strength, YS', MPa (ksi)	404.7 (58.7)	
Cyclic strength coefficient, K', MPa (ksi):	1,447.6 (210.0)	
Cyclic strain hardening exponent, n':	0.2051	

\* Correction was made according to the Bridgman correction factor.

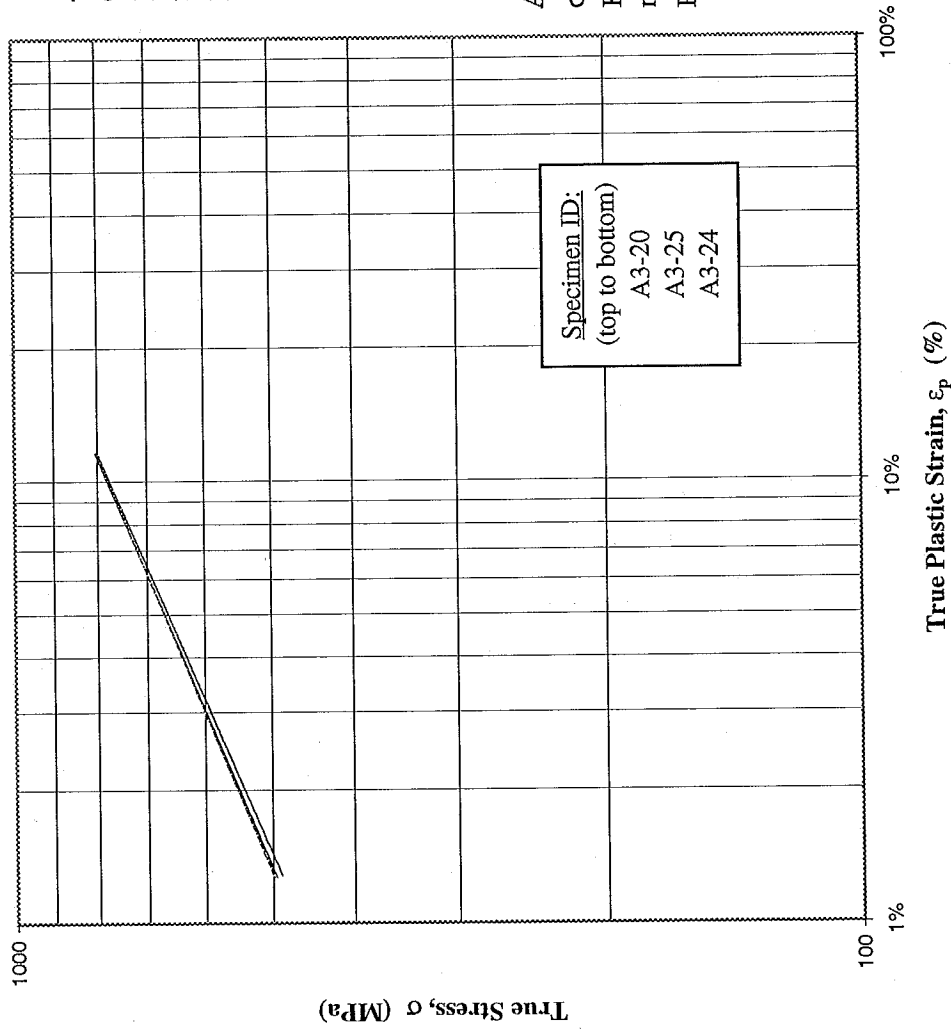

Figure 2: Photomicrograph in the longitudinal direction (L-T) at 500X for SAE 1141 (NbFG) normalized steel (rolling direction is horizontal)



Figure 3: Example of inclusions in the rolling direction at 100X for SAE 1141 (NbFG) normalized steel (rolling direction is horizontal)

### True Stress vs. True Plastic Strain



A3-20:  
 $\sigma = 1274.9(\epsilon_p)^{0.2151}$   
 $K = 1274.9$  MPa  
 $n = 0.2151$   
 $R^2 = 0.989$

A3-25:  
 $\sigma = 1289.6(\epsilon_p)^{0.2193}$   
 $K = 1289.6$  MPa  
 $n = 0.2193$   
 $R^2 = 0.989$

A3-24:  
 $\sigma = 1295.9(\epsilon_p)^{0.2242}$   
 $K = 1295.9$  MPa  
 $n = 0.2242$   
 $R^2 = 0.989$

Figure 4: True stress versus true plastic strain

Engineering Stress vs. Engineering Strain

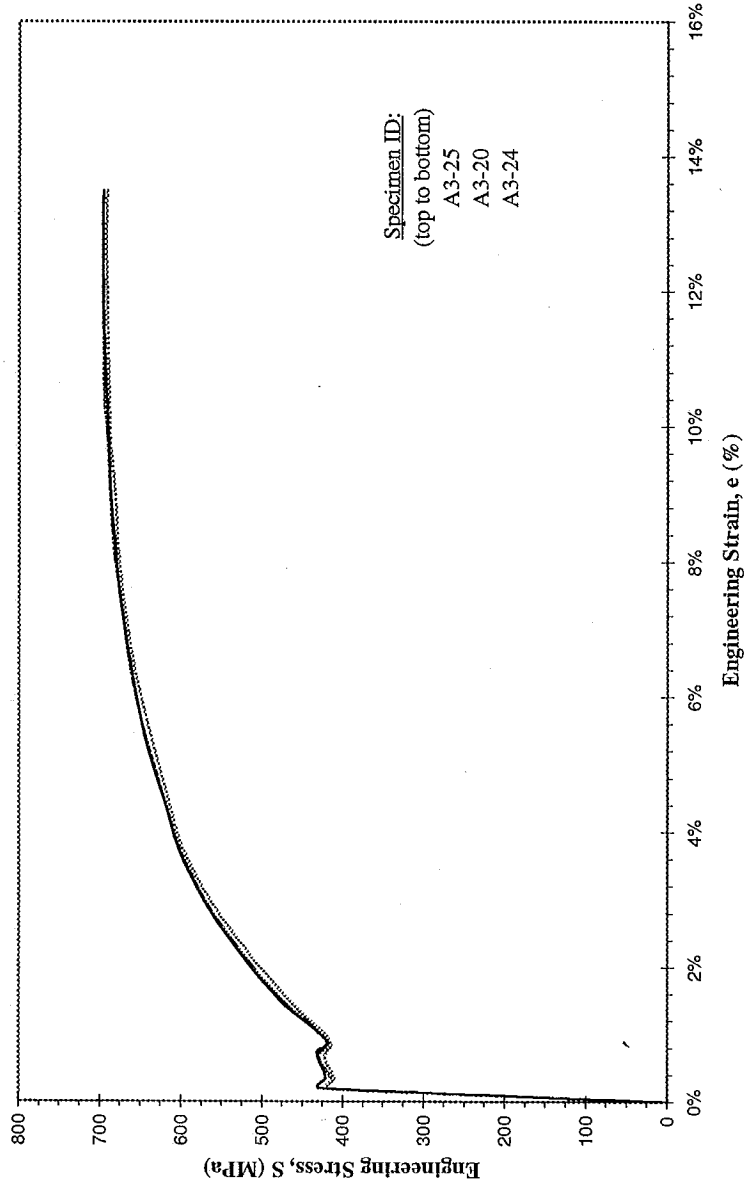

Figure 5: Monotonic stress-strain curve

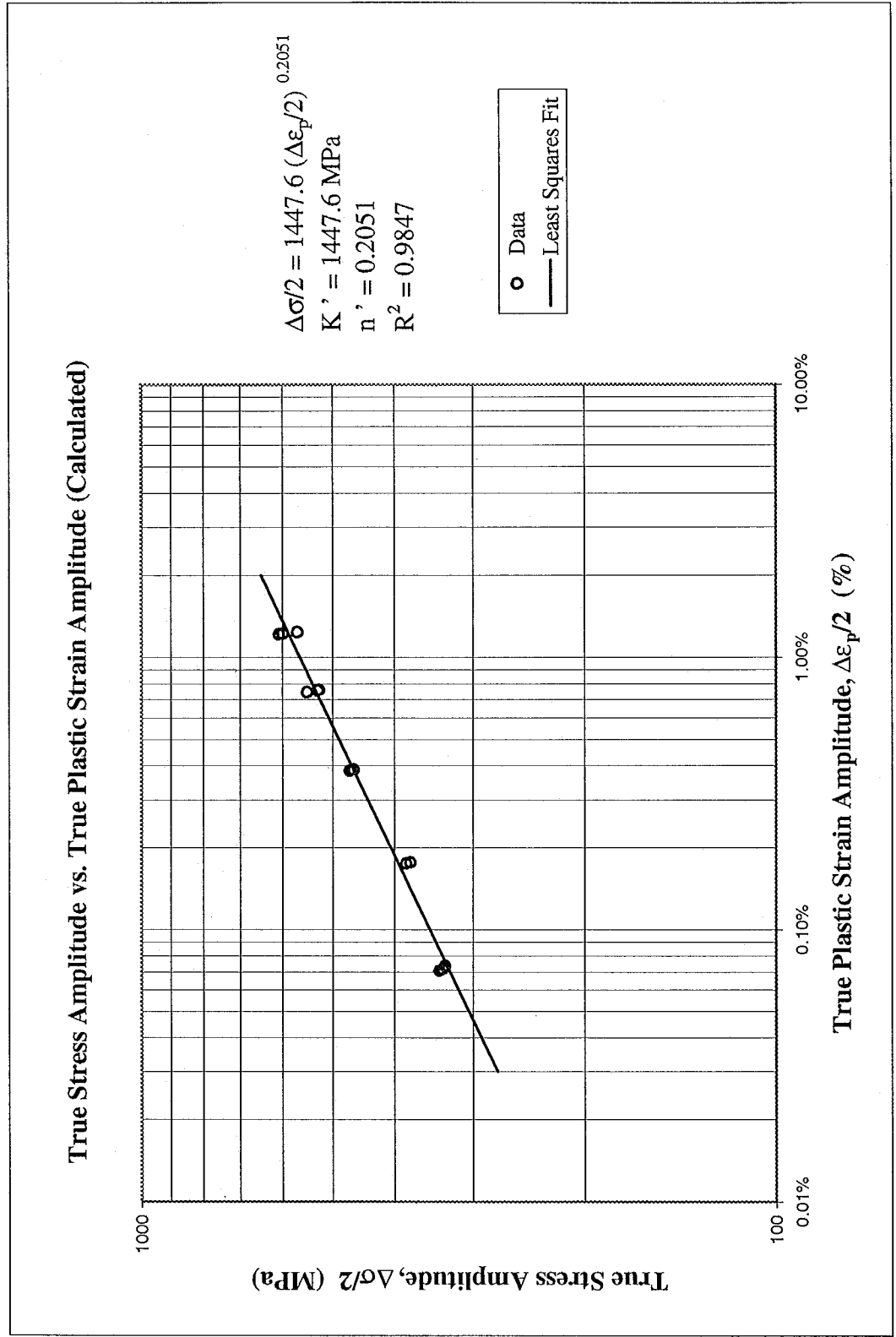

Figure 6: True stress amplitude versus calculated true plastic strain amplitude



### True Stress Amplitude vs. True Strain Amplitude

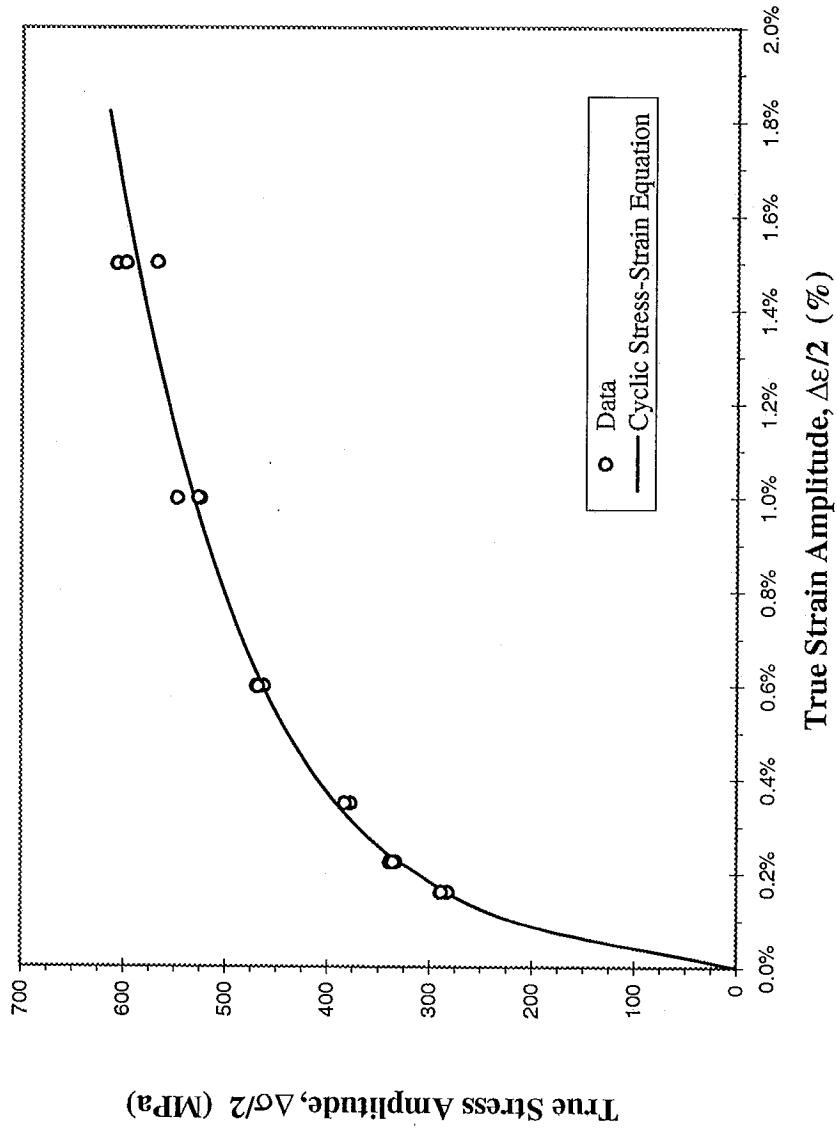

Figure 7: True stress amplitude versus true strain amplitude

### Composite Plot of Monotonic and Cyclic Stress-Strain Curves

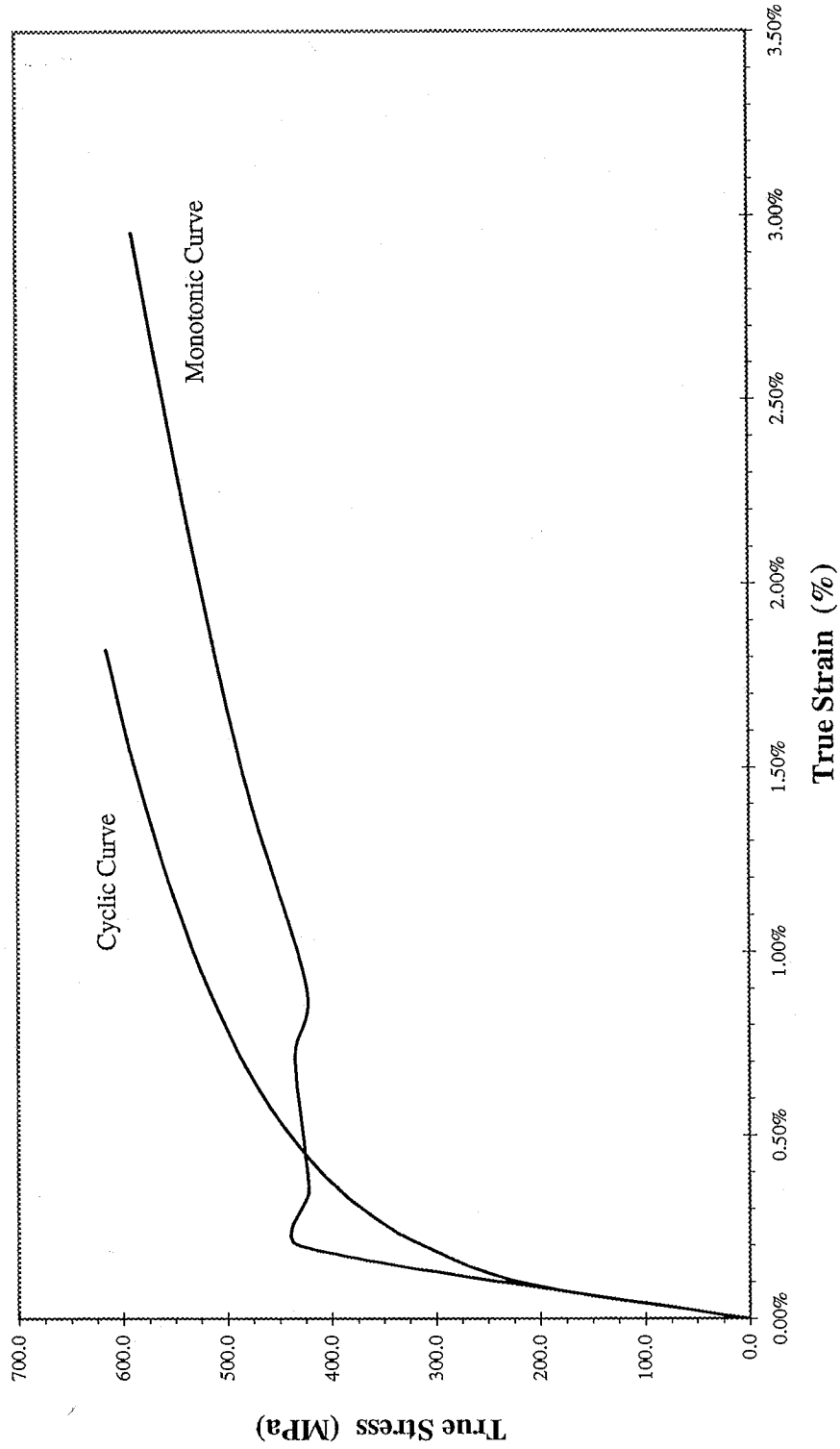

Figure 8: Composite plot of cyclic and monotonic stress-strain curves

### True Stress Amplitude vs. Reversals to Failure

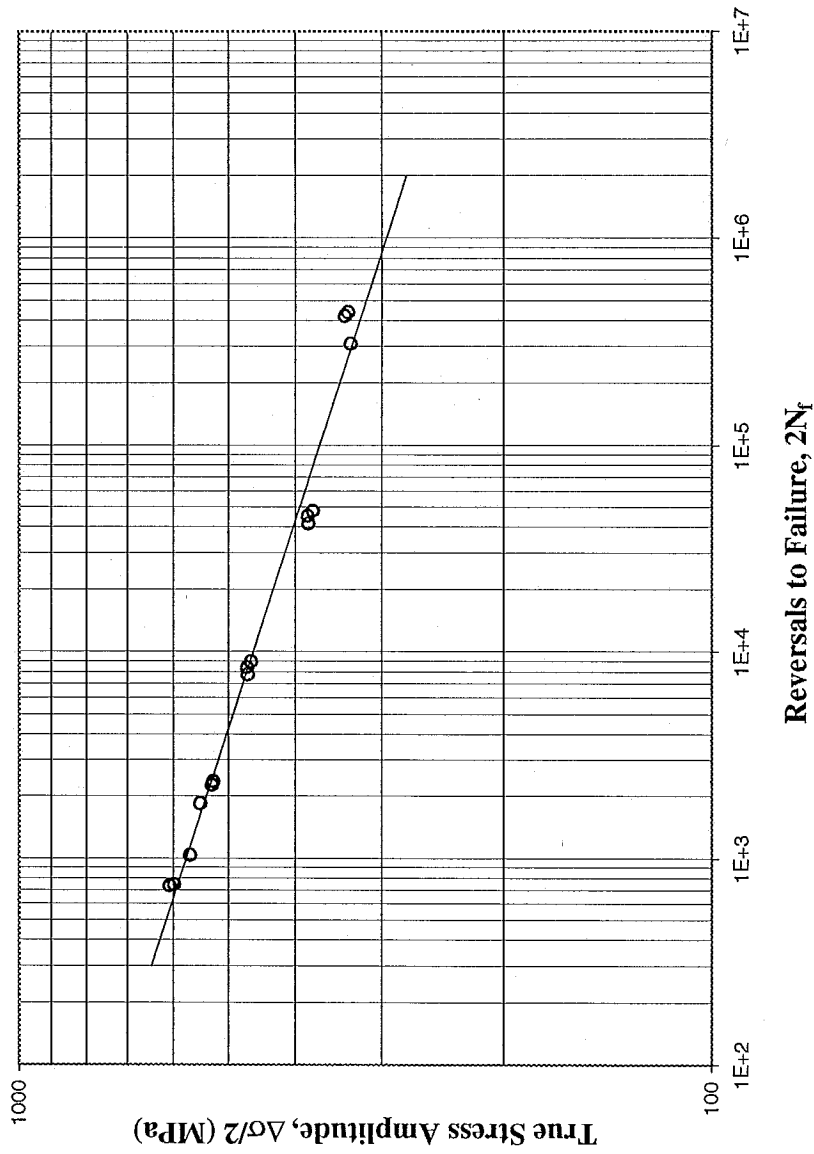

Figure 9: True stress amplitude versus reversals to failure

### True Plastic Strain Amplitude (Calculated) vs. Reversals to Failure

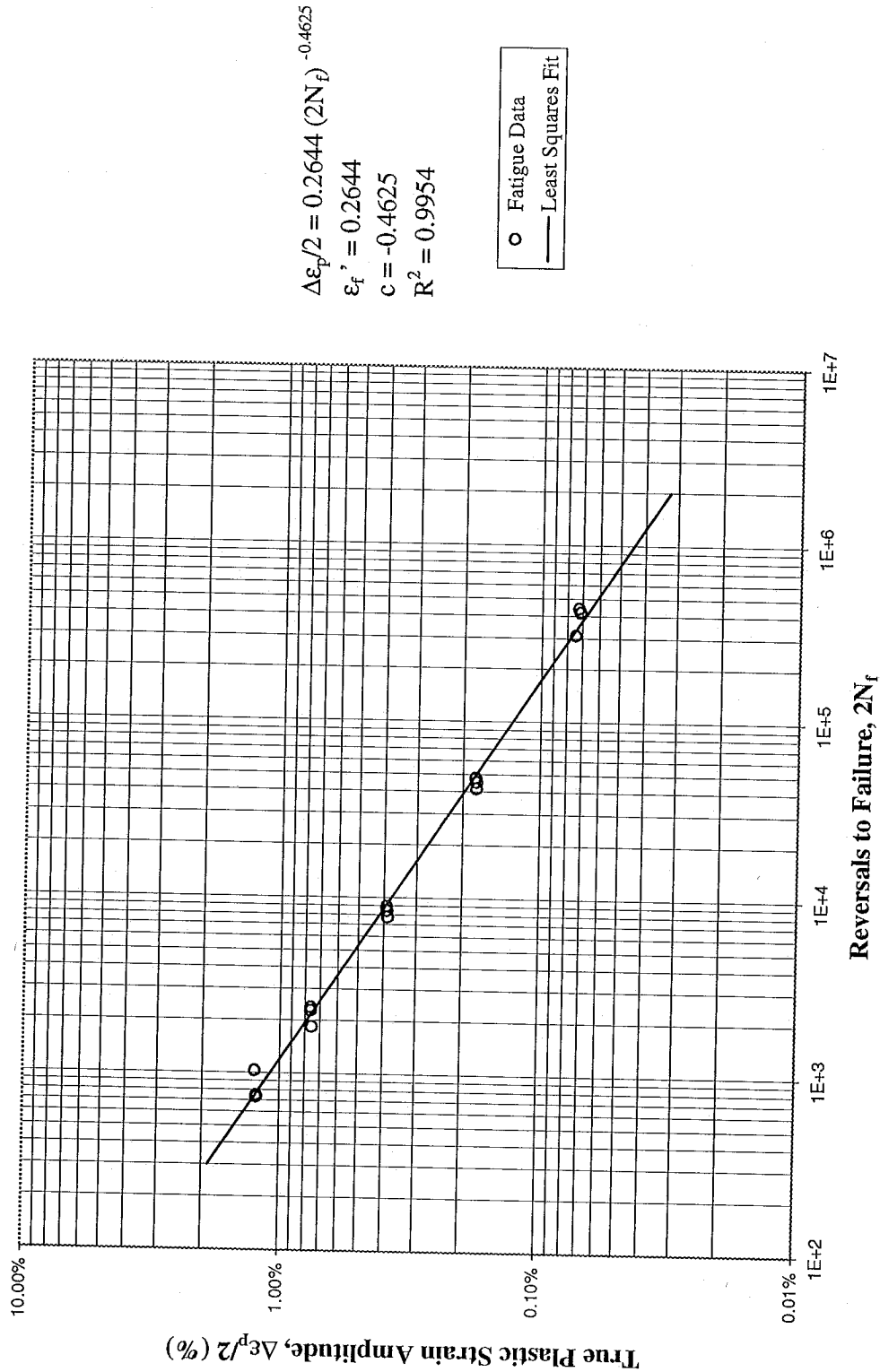

Figure 10: Calculated true plastic strain amplitude versus reversals to failure

True Strain Amplitude vs. Reversals to Failure

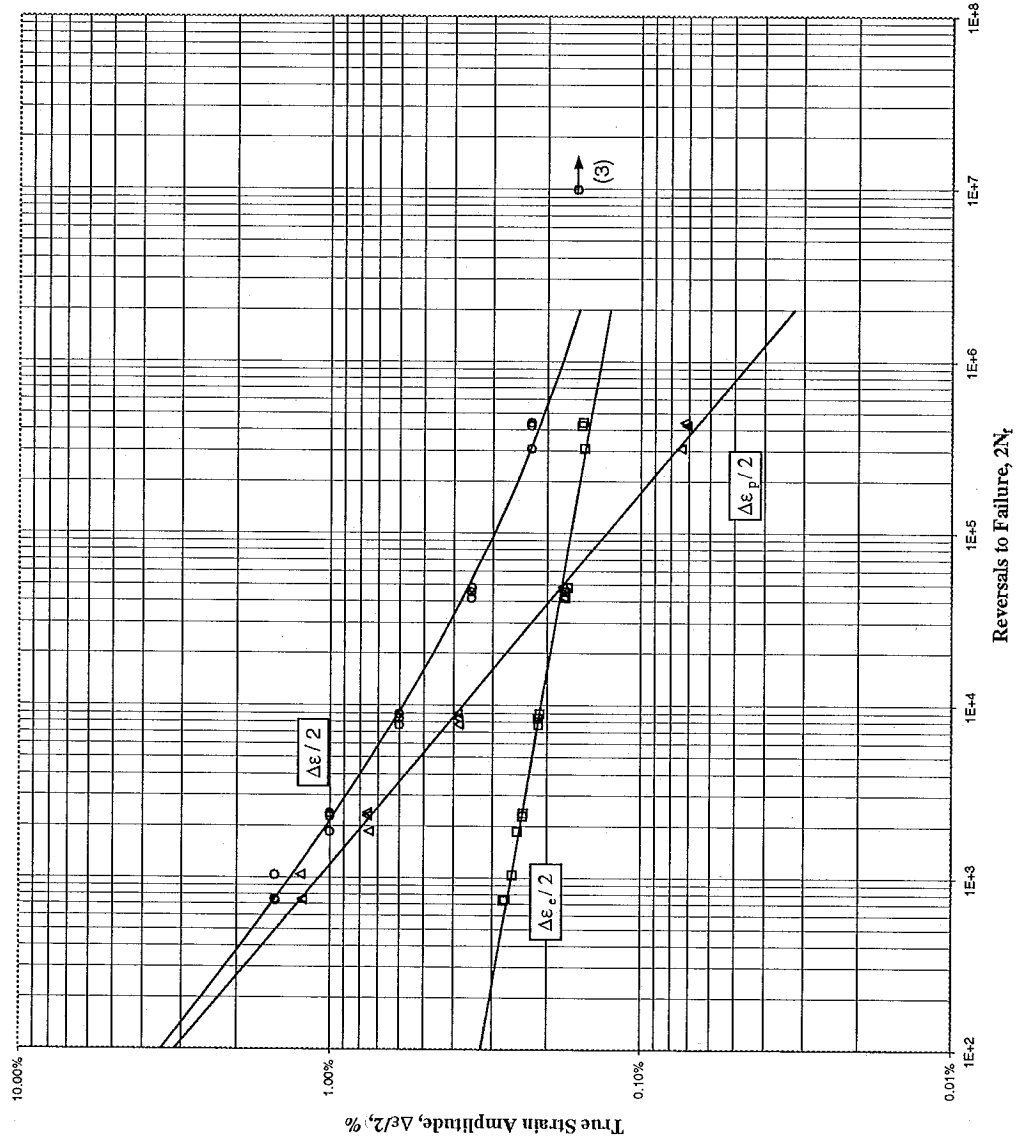

Figure 11: True strain amplitude versus reversals to failure

## REFERENCES

- [1] ASTM Standard E606-92, "Standard Practice for Strain-Controlled Fatigue Testing," Annual Book of ASTM Standards, Vol. 03.01, 1997, pp. 523-537.
- [2] ASTM Standard E83-96, "Standard Practice for Verification and Classification of Extensometers," Annual Book of ASTM Standards, Vol. 03.01, 1997, pp. 198-206.
- [3] ASTM Standard E1012-93a, "Standard Practice for Verification of Specimen Alignment Under Tensile Loading," Annual Book of ASTM Standards, Vol. 03.01, 1997, pp. 699-706.
- [4] ASTM Standard E8-96a, "Standard Test Methods for Tension Testing of Metallic Materials," Annual Book of ASTM Standards, Vol. 03.01, 1997, pp. 56-76.
- [5] Park, J. and Song, J., "Detailed Evaluation of Methods for Estimation of Fatigue Properties," *International Journal of Fatigue*, Vol. 17, No. 5, 1995, pp. 365-373.
- [6] ASTM Standard E112-96, "Standard Test Methods for Determining Average Grain Size," Annual Book of ASTM Standards, Vol. 03.01, 1997, pp. 227-249.
- [7] ASTM Standard E45-97, "Standard Test Methods for Determining the Inclusion Content of Steel," Annual Book of ASTM Standards, Vol. 03.01, 1997, pp. 157-170.
- [8] ASTM Standard E739-91, "Standard Practice for Statistical Analysis of Linear or Linearized Stress-Life (S-N) and Strain-Life ( $\epsilon$ -N) Fatigue Data," Annual Book of ASTM Standards, Vol. 03.01, 1995, pp. 615-621.
- [9] ASTM Standard E646-93, "Standard Test Method for Tensile Strain-Hardening Exponents (n-values) of Metallic Sheet Materials," Annual Book of ASTM Standards, Vol. 03.01, 1997, pp. 550-556.
- [10] Bridgman, P. W., "Stress Distribution at the Neck of Tension Specimen," *Transactions of American Society for Metals*, Vol. 32, 1944, pp. 553-572.

# APPENDIX

Table A.1: Summary of monotonic tensile test results

Specimen ID	D <sub>o</sub> , mm (in.)	D <sub>f</sub> , mm (in.)	L <sub>o</sub> , mm (in.)	L <sub>f</sub> , mm (in.)	E, GPa (ksi)	YS MPa (ksi) (offset=0.2%)	UY5, MPa (ksi)	LYS, MPa (ksi)	YPE, %	S <sub>u</sub> , MPa (ksi)	K, MPa (ksi)	n	%EL, %	%RA, %	R, mm (in.)	σ <sub>f</sub> *, MPa (ksi)	ε <sub>f</sub>
A3-20	5.16 (0.203)	3.45 (0.136)	7.62 (0.30)	10.36 (0.41)	215.8 (31,294.0)	421.9 (61.2)	429.6 (62.3)	419.6 (60.9)	0.74%	696.5 (101.0)	1,274.9 (184.9)	0.2151	36%	55%	3.77 (0.148)	1109.0 (160.8)	81%
A3-24	5.11 (0.201)	3.56 (0.140)	7.62 (0.30)	10.31 (0.41)	225.9 (32,759.9)	412.2 (59.8)	419.0 (60.8)	410.0 (59.5)	0.72%	692.3 (100.4)	1,295.9 (187.9)	0.2243	35%	51%	4.24 (0.167)	805.5 (116.8)	72%
A3-25	5.12 (0.202)	3.50 (0.138)	7.62 (0.30)	10.11 (0.40)	219.0 (31,761.7)	419.2 (60.8)	419.2 (60.8)	412.4 (59.8)	0.72%	696.8 (101.1)	1,289.6 (187.0)	0.21293	33%	53%	4.23 (0.167)	1083.8 (157.2)	76%
Average values					220.2 (31,938.5)	417.8 (60.6)	422.6 (61.3)	414.0 (60.0)	0.73%	695.2 (100.8)	1,286.8 (186.6)	0.2174	35%	53%		999.5 (145.0)	76%

\* The values of true fracture strength are corrected for necking according to the Bridgman correction factor.



**Table A.2: Summary of constant amplitude completely reversed fatigue test results**

Specimen ID	Test control mode	Test freq., Hz	E, GPa (ksi)	At midlife ( $N_{50\%}$ )						$N_{50\%}$ , [b] cycles	$(N_f)_{10\%}$ , [c] cycles	$(N_f)_{50\%}$ , [d] cycles	Failure location [e]
				E', GPa (ksi)	$\Delta\epsilon/2$ , %	$\Delta\epsilon_p/2$ [a] (calculated), %	$\Delta\epsilon_p/2$ (measured), %	$\Delta\sigma/2$ , MPa (ksi)	$\sigma_m$ , MPa (ksi)				
A3-23	strain	0.33	211.7 (30,709.0)	200.0 (29,004.5)	1.499%	1.223%	1.182%	607.2 (88.1)	-1.8 (-0.3)	175	358	369	IGL
A3-12	strain	0.33	205.0 (29,730.0)	194.8 (28,250.0)	1.500%	1.228%	1.175%	598.2 (86.8)	-1.4 (-0.2)	175	367	376	IGL
A3-1	strain	0.33	205.9 (29,856.6)	190.7 (27,656.1)	1.501%	1.244%	1.176%	567.3 (82.3)	1.6 (0.2)	200	498	519	IGL
A3-15	strain	0.5	202.7 (29,392.2)	199.1 (28,872.6)	1.000%	0.761%	0.713%	524.9 (76.1)	0.5 (0.1)	550	1,171	1,192	IGL
A3-22	strain	0.5	202.9 (29,429.7)	192.3 (27,894.8)	1.000%	0.761%	0.714%	527.2 (76.5)	-0.9 (-0.1)	550	1,109	1,141	IGL
A3-3	strain	0.5	211.1 (30,617.5)	204.9 (29,718.8)	0.999%	0.751%	0.716%	547.6 (79.4)	-2.5 (-0.4)	500	927	927	IGL
A3-21	strain	0.83	210.9 (30,591.9)	200.4 (29,062.4)	0.600%	0.390%	0.362%	462.9 (67.1)	1.5 (0.2)	2,000	4,360	4,488	IGL
A3-13	strain	0.83	210.4 (30,508.3)	208.8 (30,280.7)	0.600%	0.387%	0.372%	469.3 (68.1)	-5.4 (-0.8)	2,000	3,936	4,235	IGL
A3-2	strain	0.85	206.0 (29,881.0)	198.3 (28,761.8)	0.599%	0.386%	0.361%	468.1 (67.9)	2.9 (0.4)	2,000	3,775	3,890	IGL
A3-18	strain	1.43	214.0 (31,043.5)	187.4 (27,176.0)	0.351%	0.177%	0.143%	383.1 (55.6)	6.9 (1.0)	10,000	21,260	22,810	IGL
A3-4	strain	1.43	199.4 (28,916.6)	190.4 (27,613.3)	0.349%	0.178%	0.143%	377.0 (54.7)	8.0 (1.2)	12,500	23,468	24,130	IGL
A3-6	strain	1.5	209.6 (30,400.5)	191.3 (27,738.5)	0.350%	0.176%	0.145%	382.9 (55.5)	5.9 (0.9)	10,000	20,206	21,000	IGL
A3-5	strain	2.22	210.3 (30,494.7)	198.4 (28,773.6)	0.225%	0.074%	0.053%	332.7 (48.2)	21.1 (3.1)	75,000	155,900	156,400	IGL
A3-7	strain	3	208.4 (30,225.9)	199.8 (28,977.3)	0.225%	0.071%	0.055%	338.7 (49.1)	13.6 (2.0)	85,000	205,128	211,500	IGL
A3-8	strain	3	208.6 (30,257.1)	196.0 (28,422.2)	0.225%	0.072%	0.055%	335.3 (48.6)	14.0 (2.0)	104,000	220,700	221,620	IGL
A3-9	load	30	210.5 (30,522.1)	208.1 (30,175.0)	0.160%	0.032%	0.021%	281.5 (40.8)	29.0 (4.2)	201,000	--	> 5,000,000	no failure
A3-10	load	30	212.7 (30,842.9)	208.2 (30,199.8)	0.160%	0.029%	0.021%	288.3 (41.8)	36.3 (5.3)	281,300	--	> 5,000,000	no failure
A3-16	load	30	214.0 (31,037.8)	216.4 (31,385.2)	0.160%	0.029%	0.023%	287.6 (41.7)	45.7 (6.6)	200,000	--	> 5,000,000	no failure

[a]  $\Delta\epsilon_p/2$  (calculated) =  $\Delta\epsilon/2 - \Delta\sigma/2E$

[b]  $N_{50\%}$  is defined as the midlife cycle (for run-out tests, data is taken from the stable cycle indicated).

[c]  $(N_f)_{10\%}$  is defined as 10% load drop.

[d]  $(N_f)_{50\%}$  is defined as 50% load drop.

[e] IGL = inside gage length; AKP = at knife point; OGIT = outside gage length but inside test section.

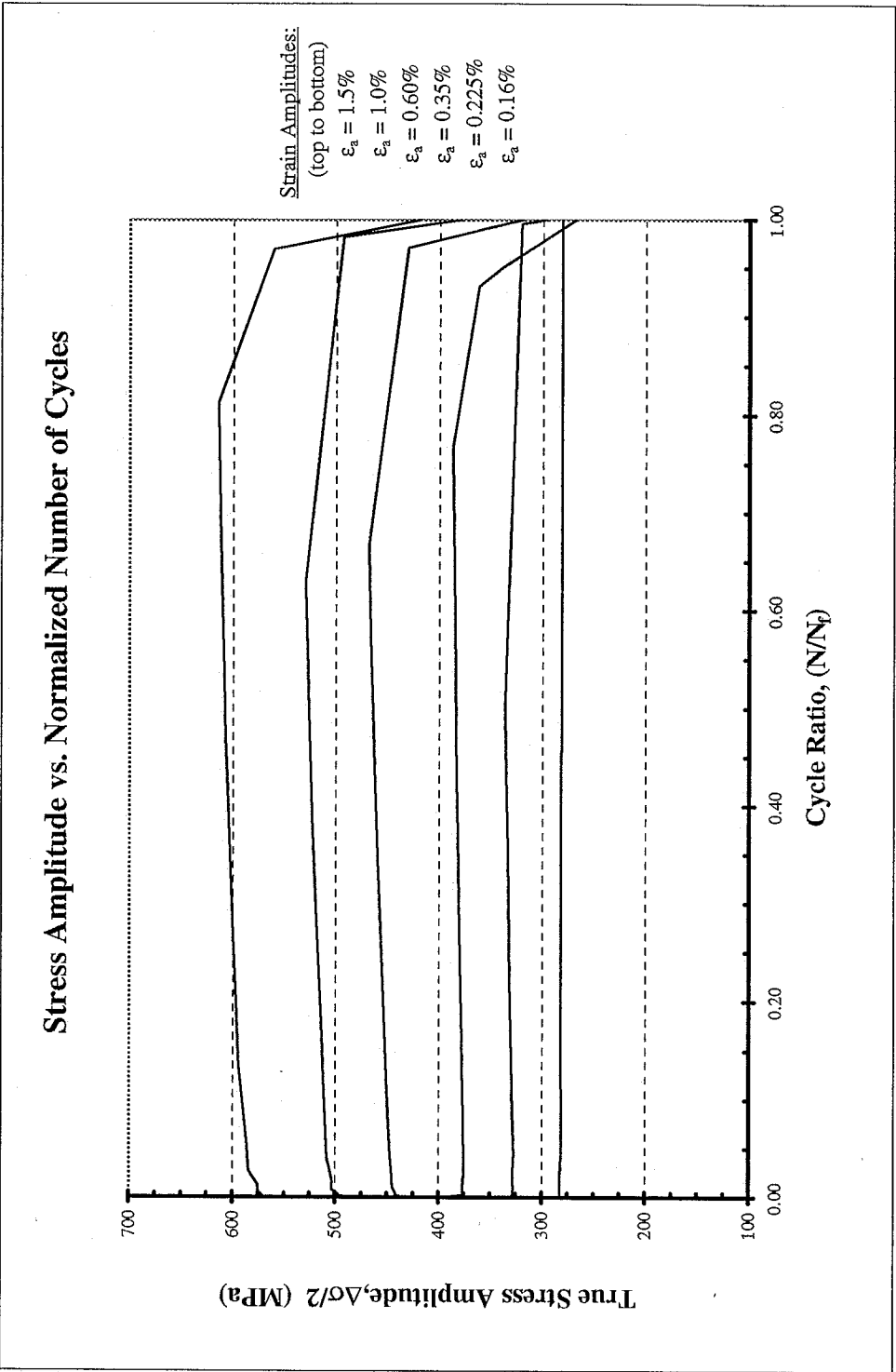

Figure A.1a: True stress amplitude versus normalized number of cycles

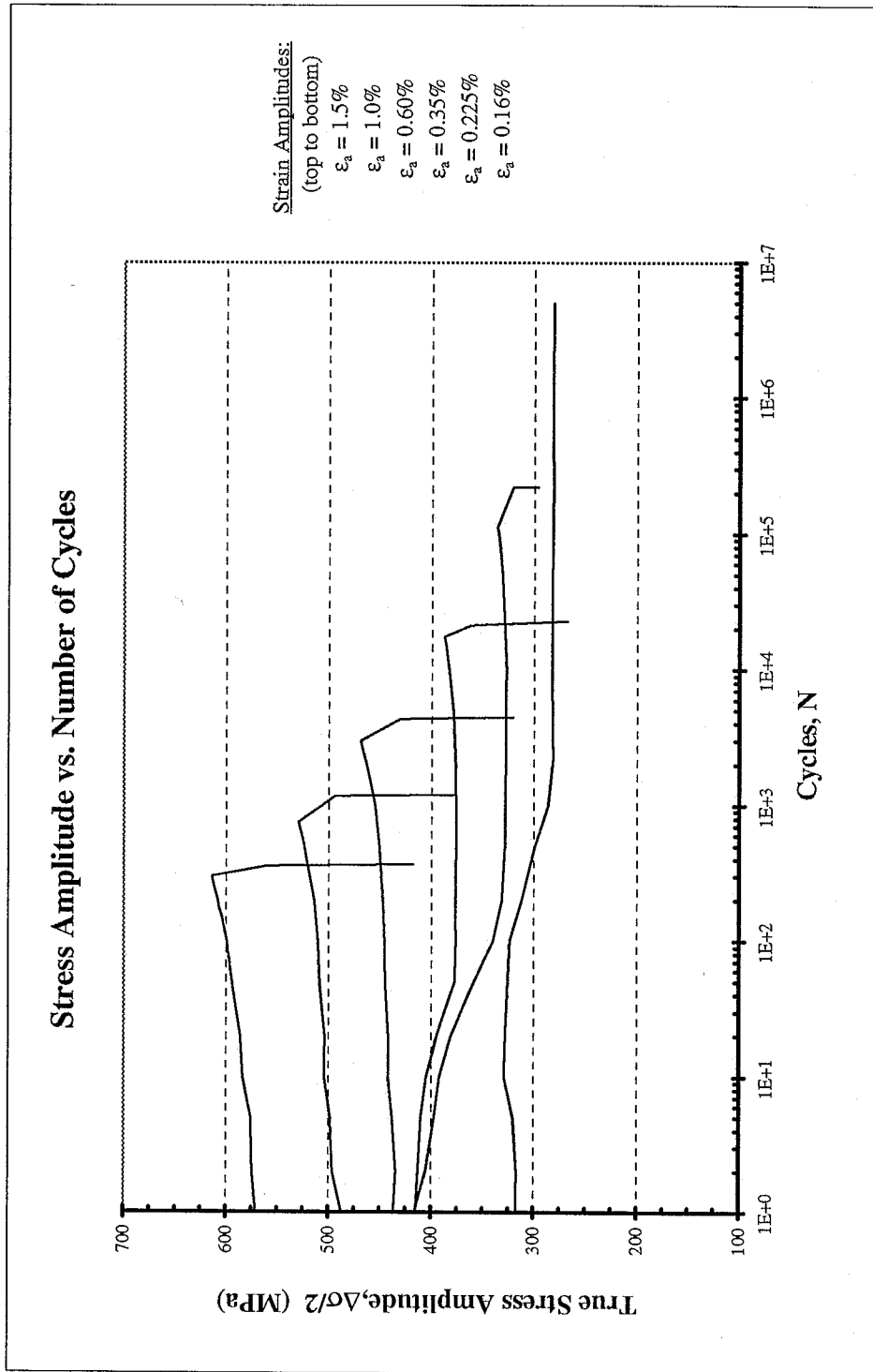
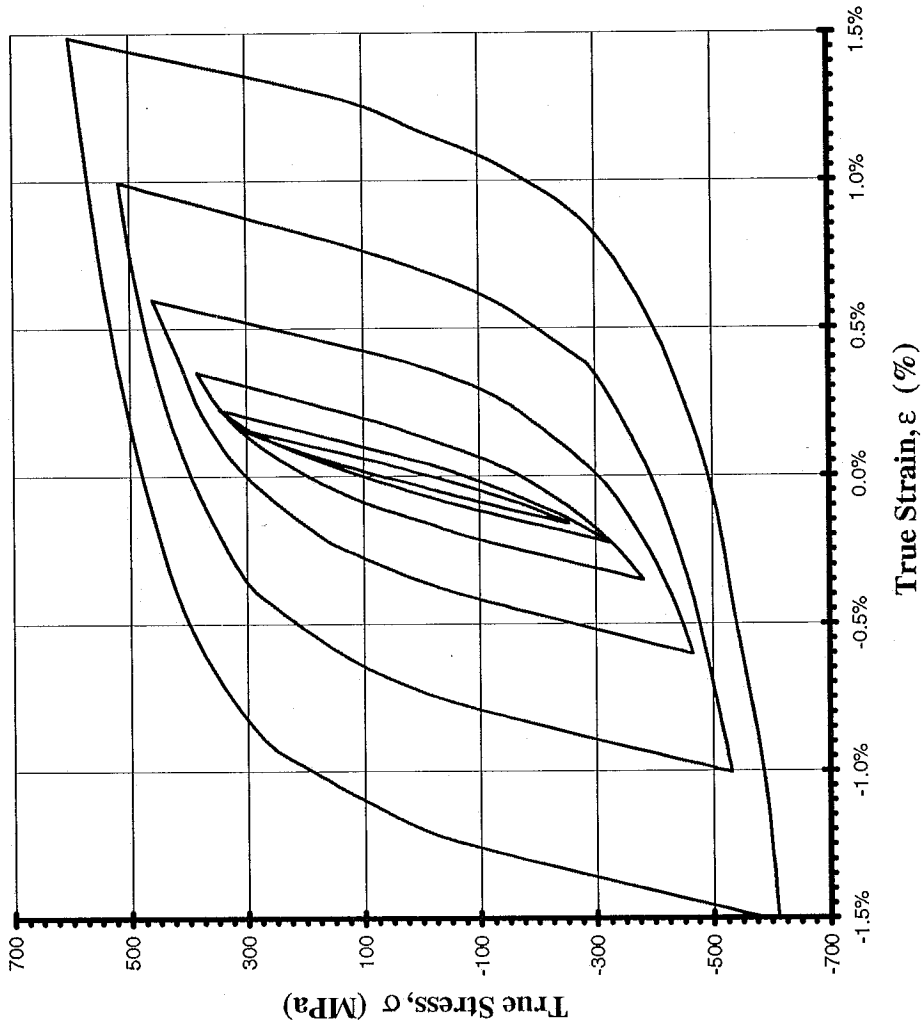

Figure A.1b: True stress amplitude versus number of cycles

### Composite Plot of Midlife Hysteresis Loops



Strain Amplitudes:  
(starting on outside)  
 $\epsilon_a = 1.5\%$   
 $\epsilon_a = 1.0\%$   
 $\epsilon_a = 0.60\%$   
 $\epsilon_a = 0.35\%$   
 $\epsilon_a = 0.225\%$   
 $\epsilon_a = 0.16\%$

Figure A.2: Composite plot of midlife hysteresis loops